

Embedded Systems

1. Introduction

Lothar Thiele

Organization

- ▶ **WWW:** <http://www.tik.ee.ethz.ch/tik/education/lectures/ES/>
- ▶ **Lecture:** Lothar Thiele, thiele@tik.ee.ethz.ch
- ▶ **Coordination:** Jan Beutel, beutel@tik.ee.ethz.ch
- ▶ **References:**
 - ***P. Marwedel: Embedded System Design (paperback), Springer Verlag, December 2011, ISBN: 978-94-007-0256-1.***
 - ***G.C. Buttazzo: Hard Real-Time Computing Systems. Springer Verlag, 2011.***
 - W. Wolf: Computers as Components – Principles of Embedded System Design. Morgan Kaufman Publishers, 2012.
 - J. Teich: Digitale Hardware/Software Systeme, Springer Verlag, 2007.
- ▶ The slides contain material of J. Rabaey, K. Keuzer, Wayne Wolf, Peter Marwedel, Philip Koopman and from the above books of J. Teich, G.C. Buttazzo, W. Wolf and P. Marwedel.

Communicating Embedded Systems

- ▶ Example: BTnodes
 - complete platform including OS
 - especially suited for pervasive computing applications



Sensor
Actuator

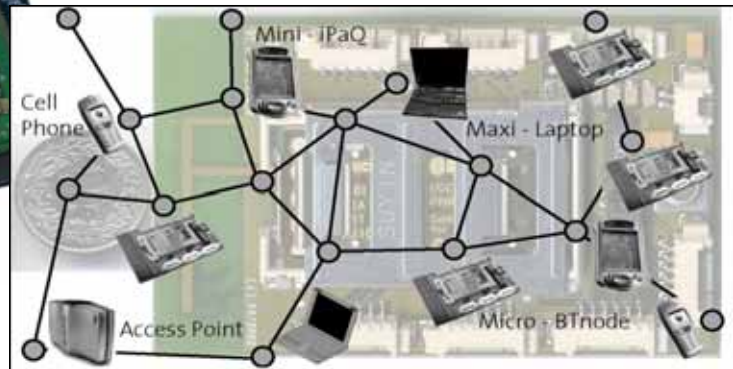
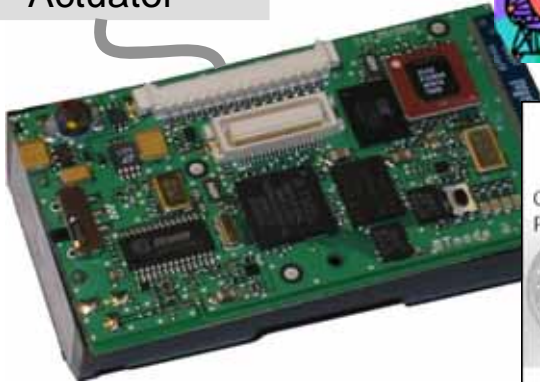

BTnode Platform

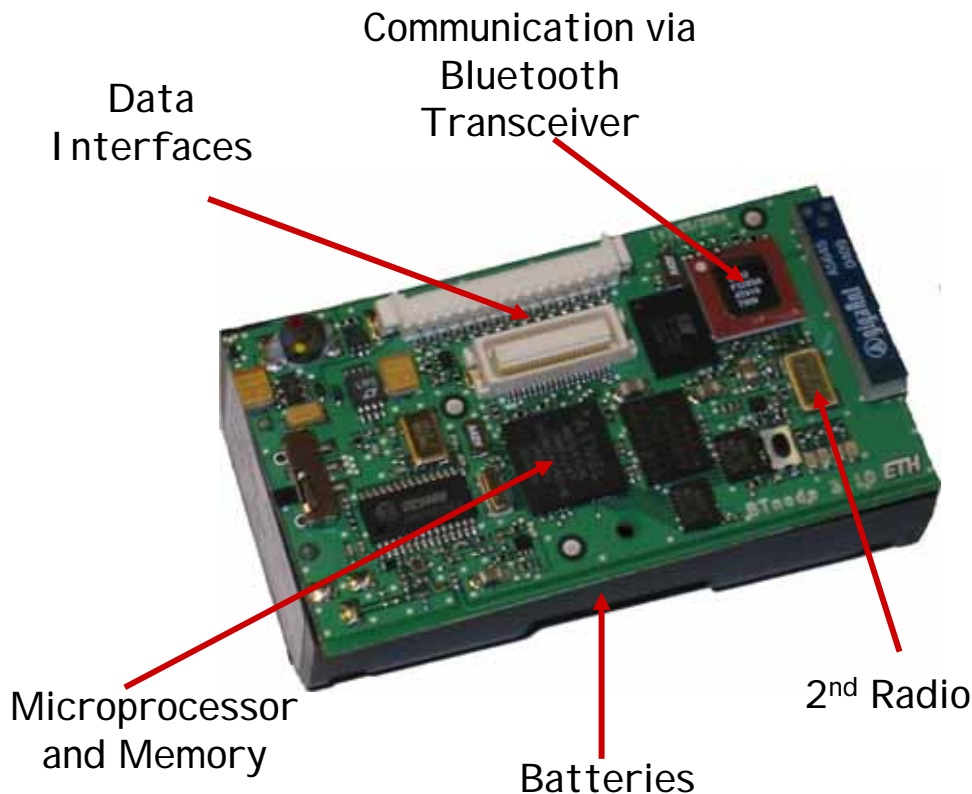

- ▶ generic platform for ad-hoc computing
- ▶ complete platform including OS
- ▶ especially suited for pervasive computing applications

Communicating Embedded Systems

- sensor networks (civil engineering, buildings, environmental monitoring, traffic, emergency situations)
- smart products, wearable/ubiquitous computing

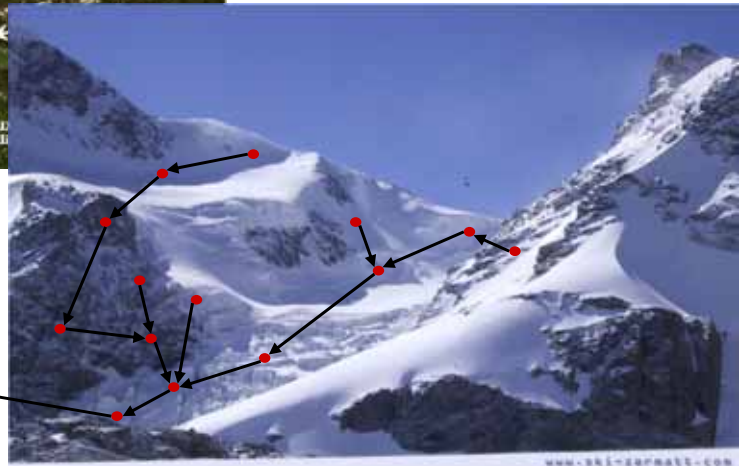
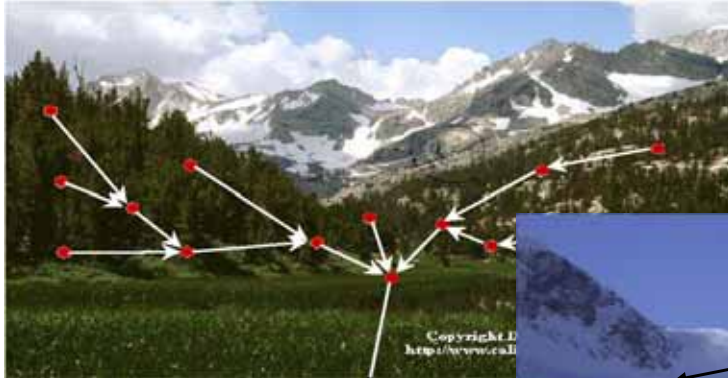

Communicating Embedded Systems

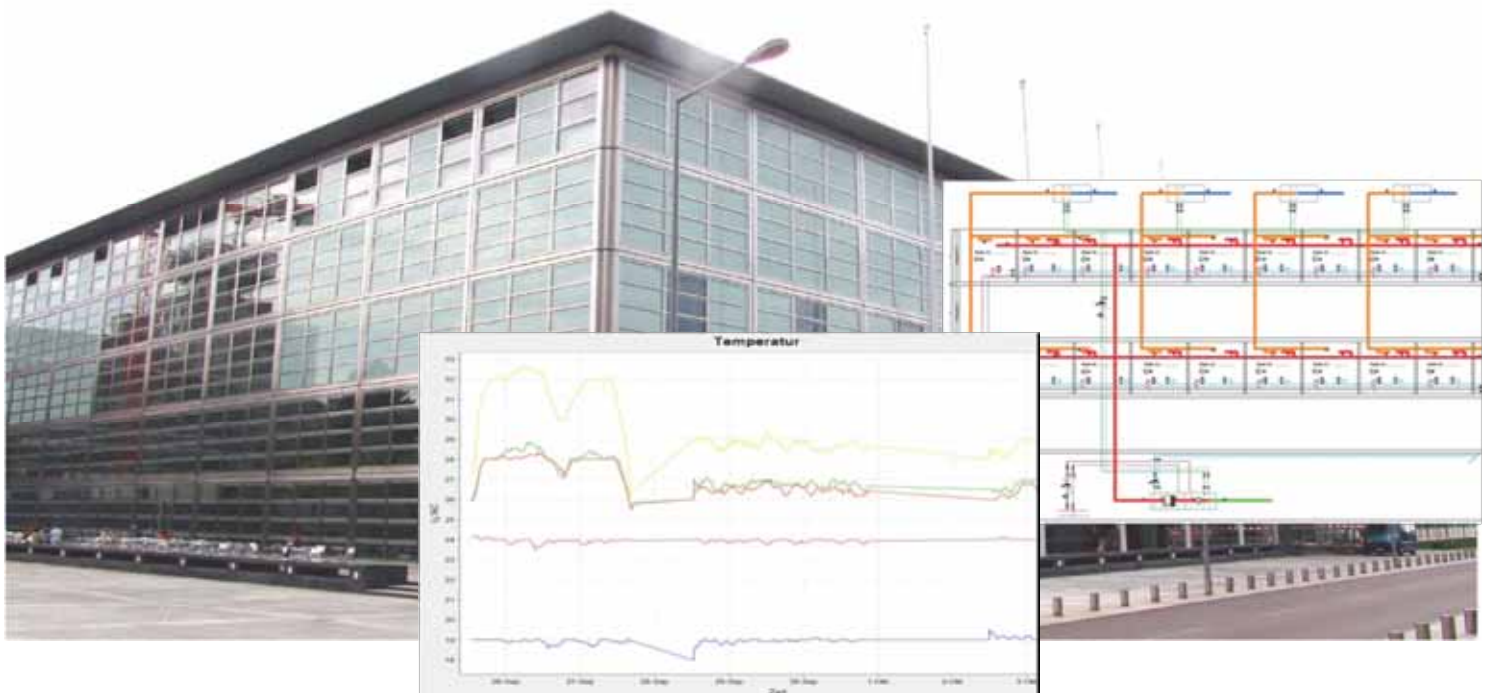

PermaSense Project

► Univ. Zurich, Univ. Basel, ETH Zurich



Hardware



Real-Time Actuating and Sensing

seismic/resistivity tomography

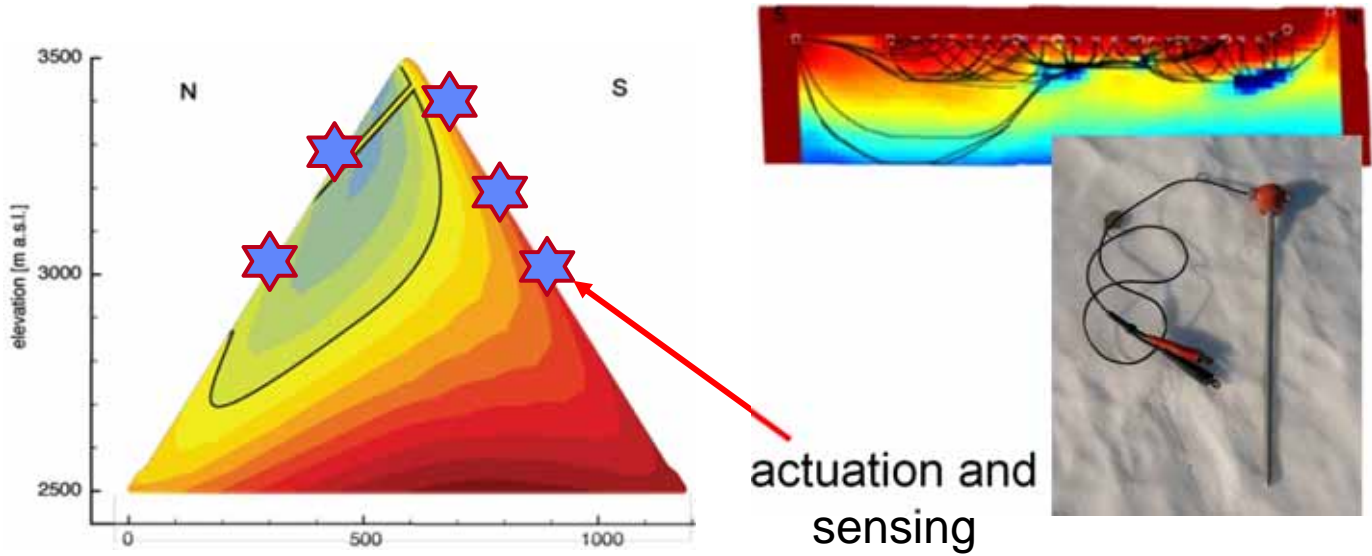

Development in ES Exercise

Linux
GNU GCC
AVR libc
Eclipse

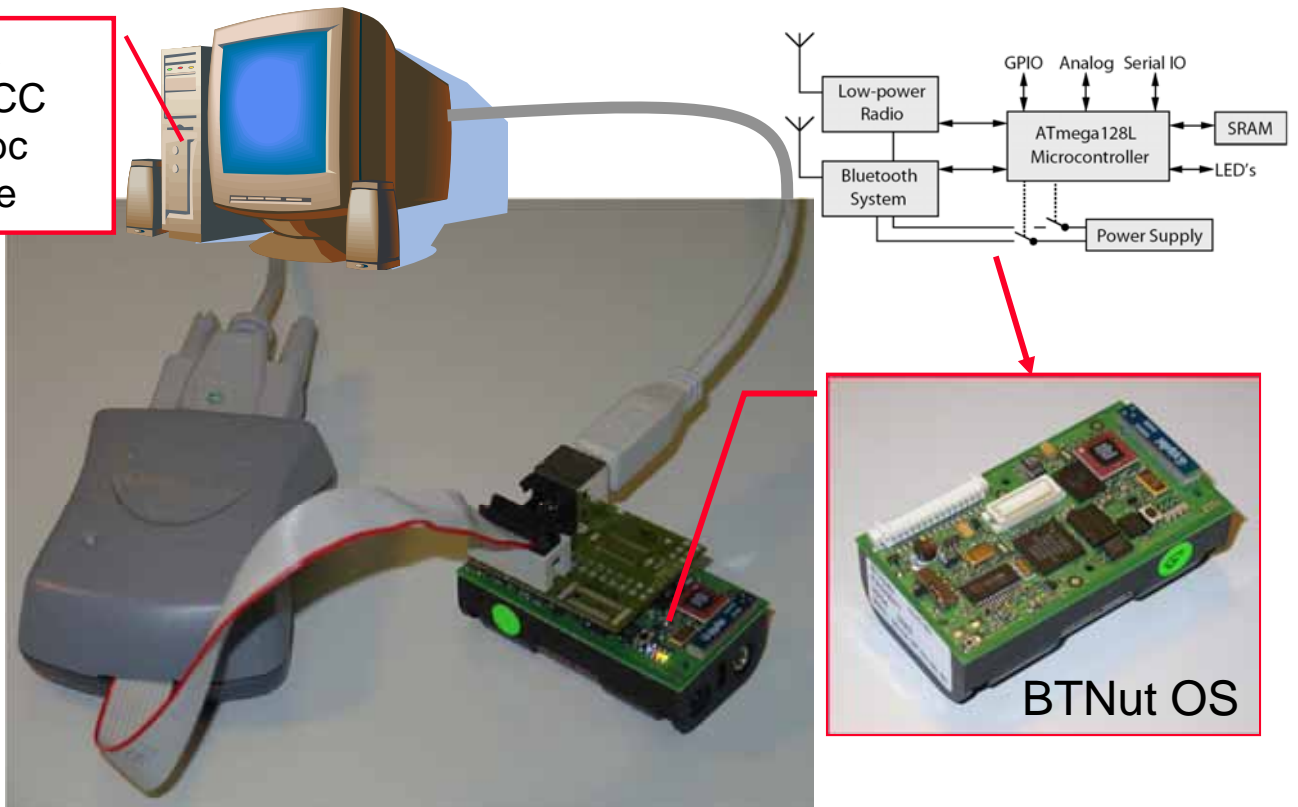

Contents of Course

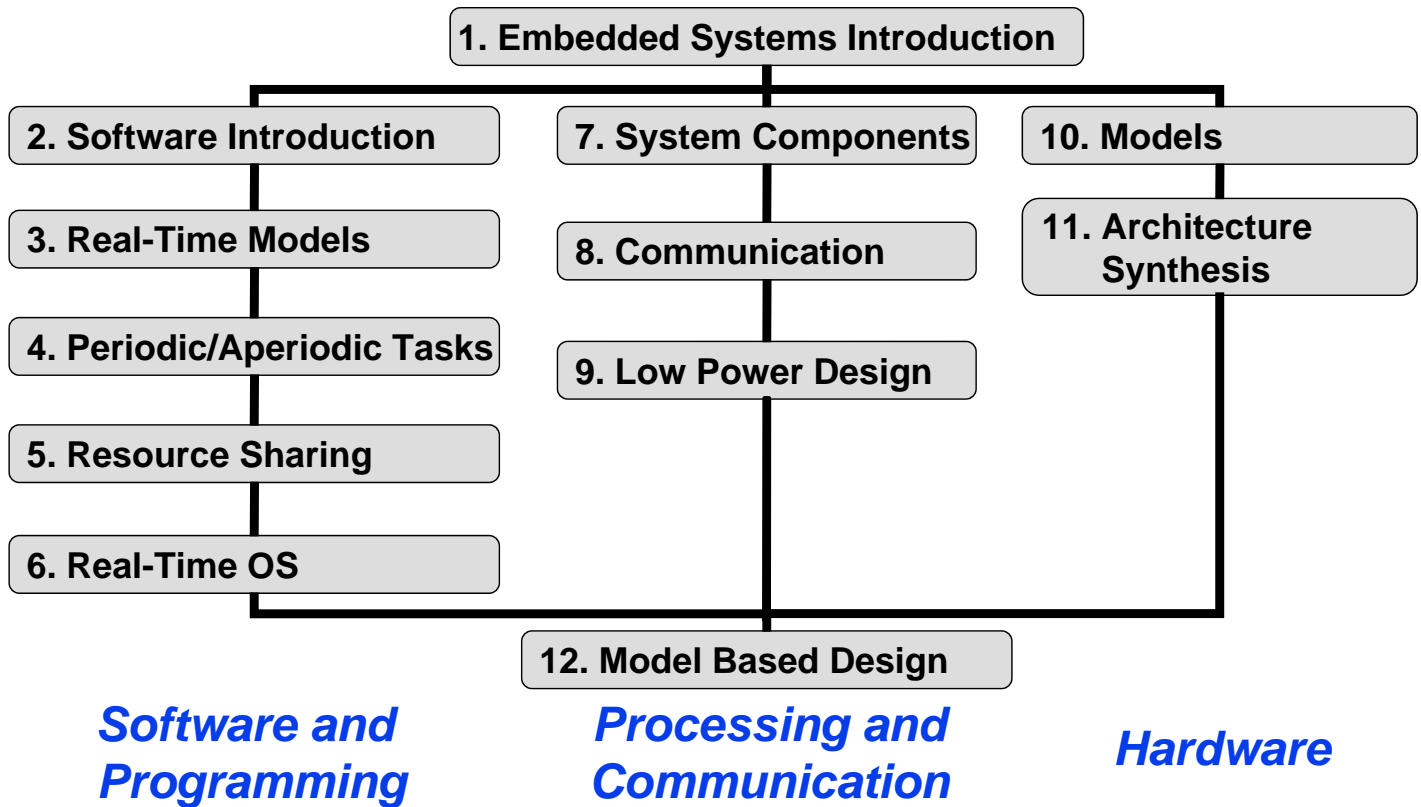

Contents of Course

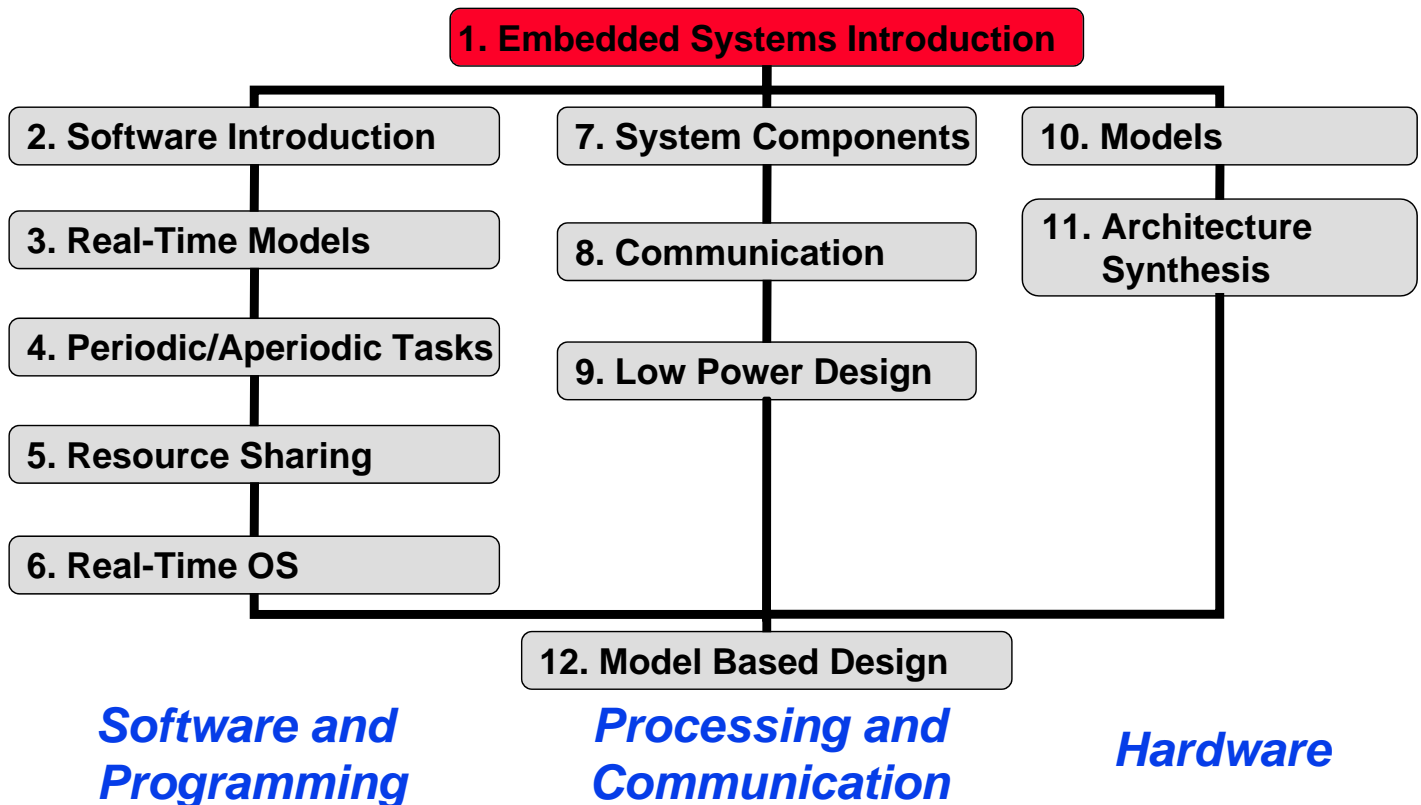

Embedded Systems

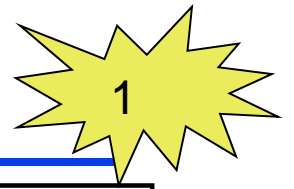

Embedded systems (ES) = information processing systems embedded into a larger product

Examples:

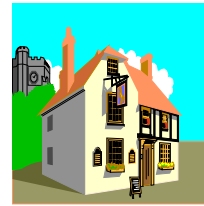

Main reason for buying is **not** information processing

Embedded Systems

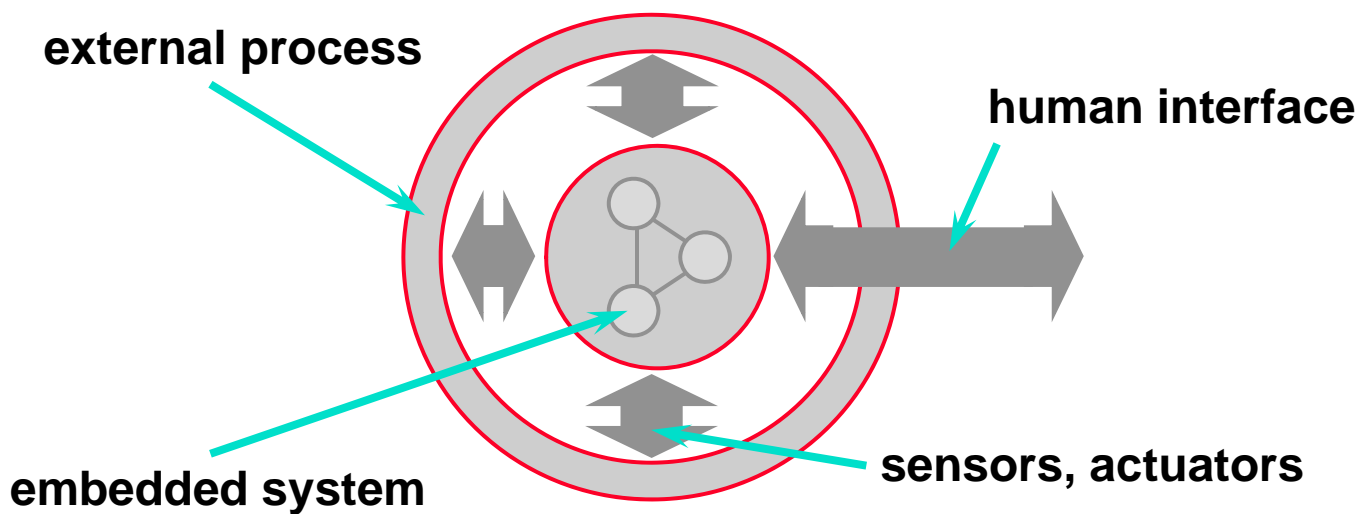

Examples of Embedded Systems

Car as an integrated control-, communication and information system.

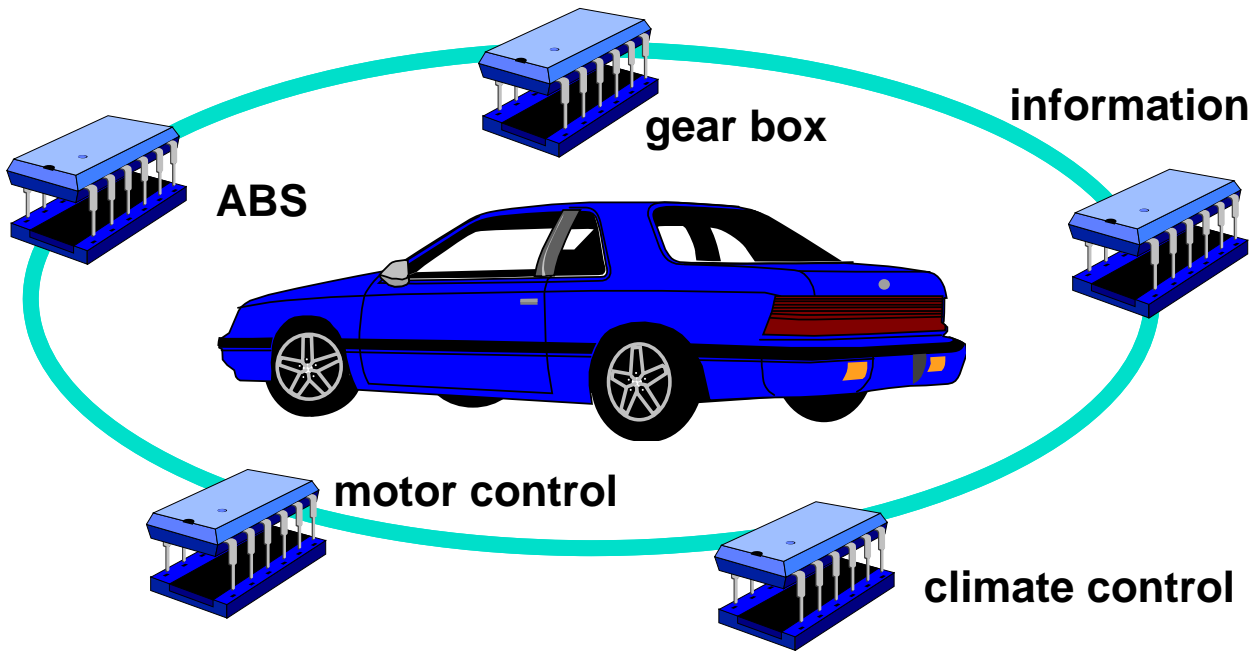

Examples of Embedded Systems

Consumer electronics, for example MP3 Audio, digital camera, home electronics,

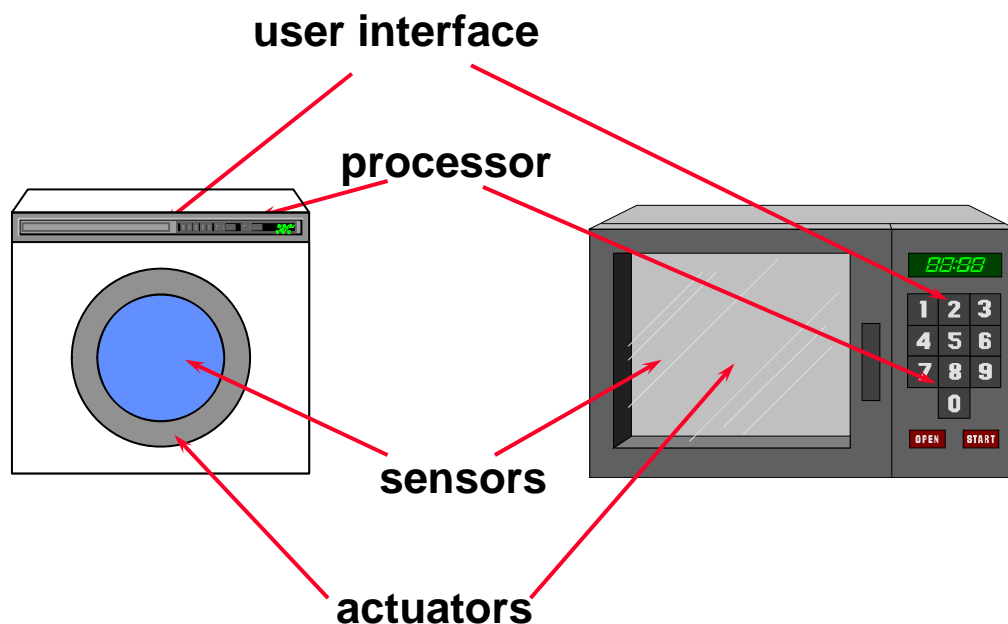

Examples of Embedded Systems

Production systems

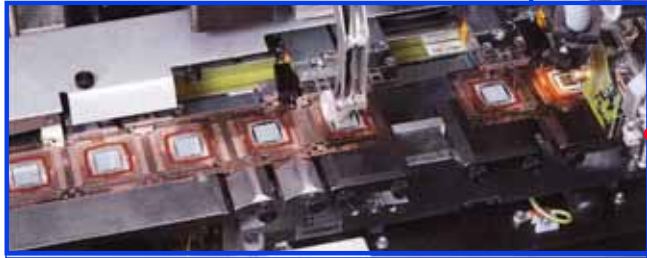

Examples of Embedded Systems

Information systems, for example wireless communication (mobile phone, Wireless LAN, ...), end-user equipment, router, ...

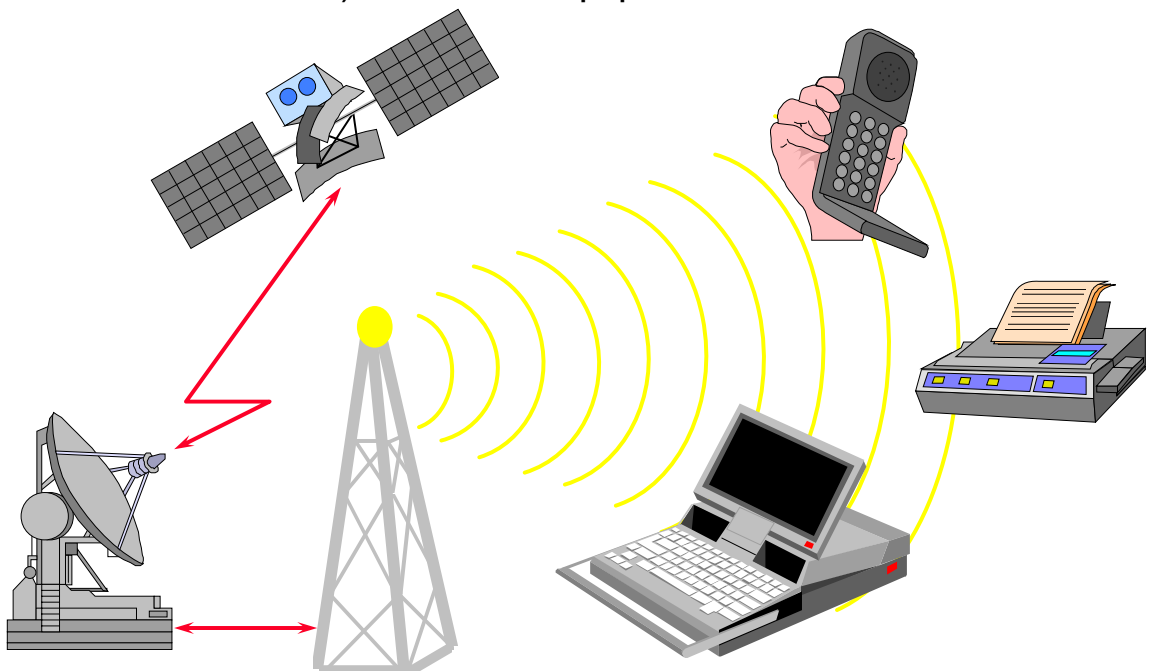

Characteristics of Embedded Systems (1)

- ▶ Must be **dependable**:
 - **Reliability**: $R(t)$ = probability of system working correctly provided that it was working at $t=0$
 - **Maintainability**: $M(d)$ = probability of system working correctly d time units after error occurred.
 - **Availability**: probability of system working at time t
 - **Safety**: no harm to be caused
 - **Security**: confidential and authentic communication

Even perfectly designed systems can fail if the assumptions about the workload and possible errors turn out to be wrong. Making the system dependable must not be an after-thought, it must be considered from the very beginning.

Characteristics of Embedded Systems (2)

- ▶ Must be **efficient**:
 - **Energy** efficient
 - **Code-size** efficient (especially for systems on a chip)
 - **Run-time** efficient
 - **Weight** efficient
 - **Cost** efficient
- ▶ **Dedicated** towards a certain **application**: Knowledge about behavior at design time can be used to minimize resources and to maximize robustness.
- ▶ **Dedicated** user **interface** (no mouse, keyboard and screen).

Characteristics of Embedded Systems (3)

- ▶ Many ES must meet **real-time constraints**:
 - A real-time system must **react to stimuli** from the controlled object (or the operator) within the time interval dictated by the environment.
 - For real-time systems, right answers arriving too late are wrong.

„A real-time constraint is called hard, if not meeting that constraint could result in a catastrophe“ [Kopetz, 1997].

- All other time-constraints are called soft.
- A **guaranteed system response** has to be explained without statistical arguments.

Characteristics of Embedded Systems (4)

- ▶ Frequently **connected to physical environment** through sensors and actuators,
- ▶ **Hybrid systems** (analog + digital parts).
- ▶ Typically, ES are **reactive systems**:

„A reactive system is one which is in continual interaction with its environment and executes at a pace determined by that environment“ [Bergé, 1995]

- Behavior depends on input and current state.
 - ☞ automata model often appropriate,

Comparison

▶ Embedded Systems

- Few applications that are known at design-time.
- Not programmable by end user.
- Fixed run-time requirements (additional computing power not useful).
- Criteria:
 - cost
 - power consumption
 - predictability
 - ...

▶ General Purpose Computing

- Broad class of applications.
- Programmable by end user.
- Faster is better.
- Criteria:
 - cost
 - average speed

“Typical” Architecture

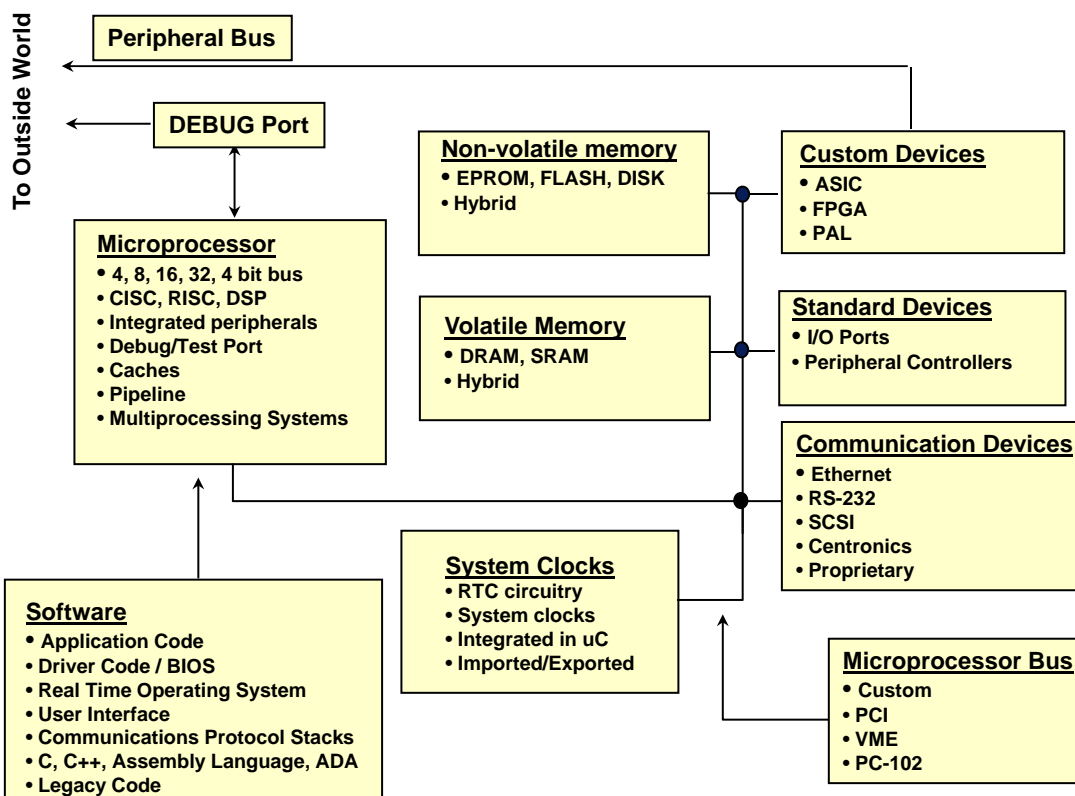

Future of Embedded Systems

- ▶ Embedded Systems overtook market of PCs.
- ▶ Ubiquitous and pervasive computing:
 - Information anytime, anywhere; building ambient intelligence into our environment; internet of things:
 - Wearable computers
 - “Smart Labels” on consumer products
 - Intelligent buildings
 - Environmental Monitoring
 - Traffic control and communicating automobiles
 - Embedded systems provide the basic technology.

Project Examples



wearable computer



Project Examples

The Obvious Choice - The Smart Home and Network Appliances

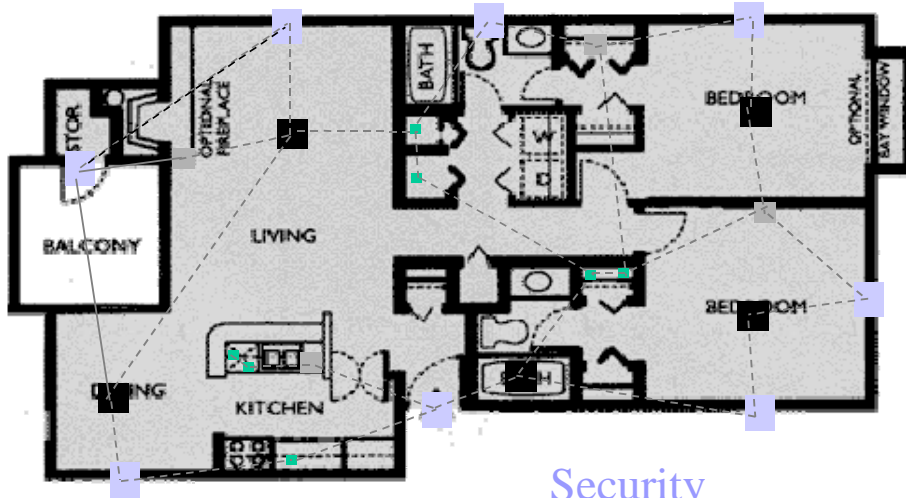

Dense network of
sensor and monitor nodes

Security
Environment monitoring and control
Object tagging
Identification

Trends ...

- ▶ Higher degree of integration
 - Microprocessor, microcontroller
 - memory + processor + I/O-units + (wireless) communication
 - System-on-chip (SoC)
 - Multiprocessor Systems on a Chip (MPSoC)
- ▶ Software increasing (amount and complexity).
- ▶ Hardware/software co-design gets increasing importance.
- ▶ Low power constraints (portable or unattended devices).
- ▶ Communicating embedded systems, very often wireless.